

DANIEL

RUBINETTERIE

MILANO

**SOFFIONE DOCCIA, BRACCIO A SOFFITTO 10 CM CON ROSONE, AERATORE
CON GETTO A PIOGGIA, ACCIAIO INOX LUCIDATO A SPECCHIO/SPAZZOLATO.**

*SHOWER HEAD, CEILING ARM 10 CM WITH PLATE, AERATOR WITH
RAIN JET, MIRROR POLISHED/BRUSHED STAINLESS STEEL.*

art. **A578PELCM10-15- 20 / SSA578PELCM10-15- 20**

IT | Istruzioni di montaggio
EN | *Assembly Instructions*

Daniel Rubinetterie S.p.A.

20062 Via Leonardo da Vinci, 53 - Cassano d'Adda (MI) Italy

Tel. +39 0363 62 651 - e-mail: info@daniel.it

www.daniel.it

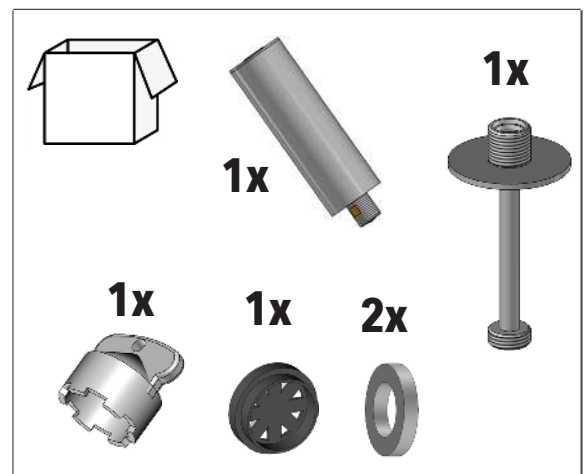
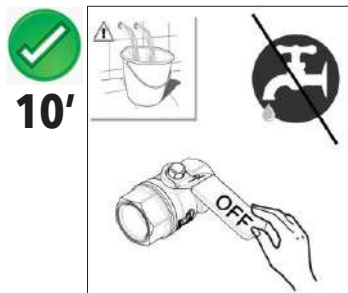
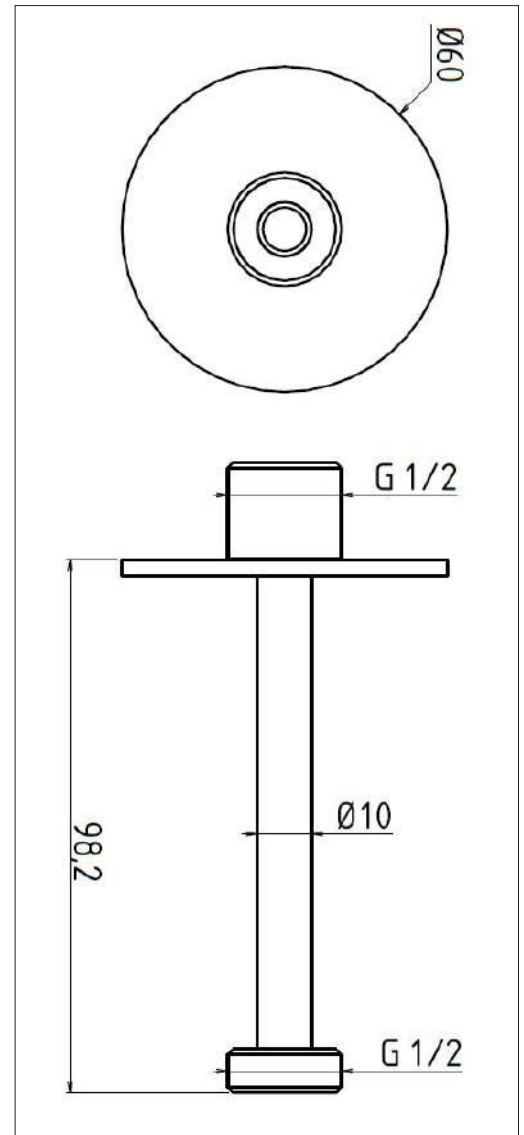
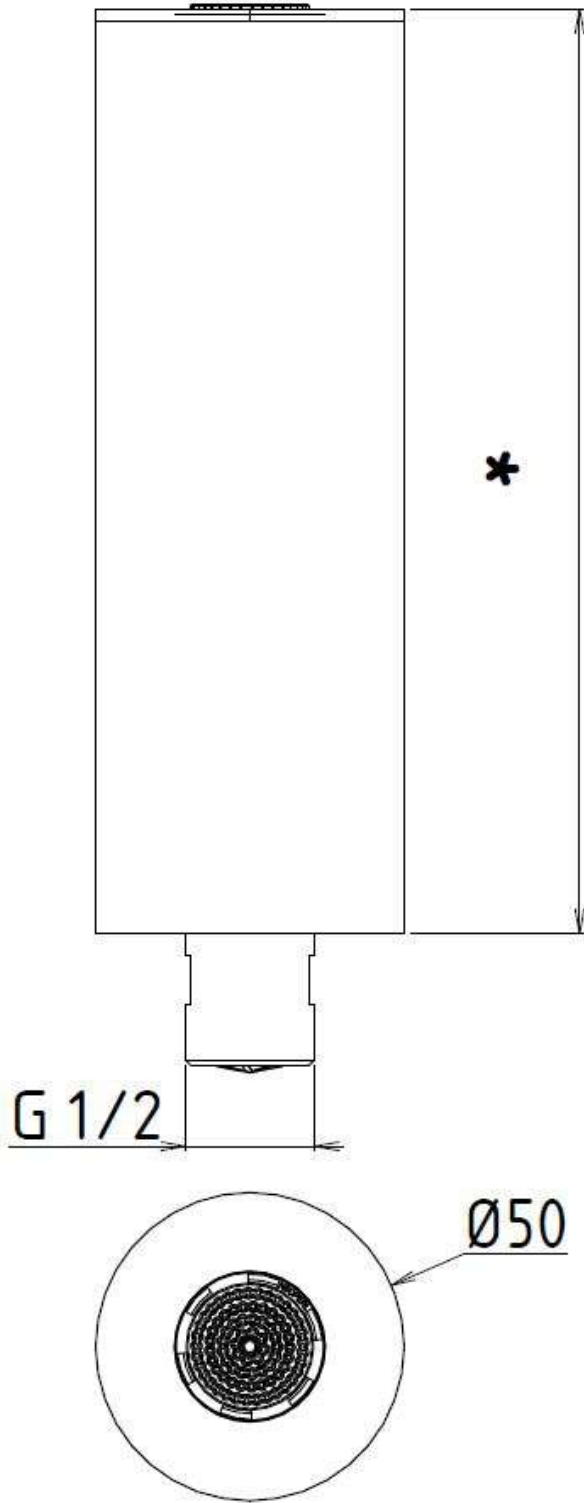

IT - L'apparechio deve essere installato da personale abilitato ai sensi e per l'effetto delle leggi in vigore.

EN - According to the law, all installation and maintenance operations require a qualified person.

DE - Das Gerät muss von qualifiziertem Personal gemäß den geltenden Gesetzen installiert werden.

FR - L'appareil doit être installé par du personnel qualifié conformément et pour l'effet des lois en vigueur.

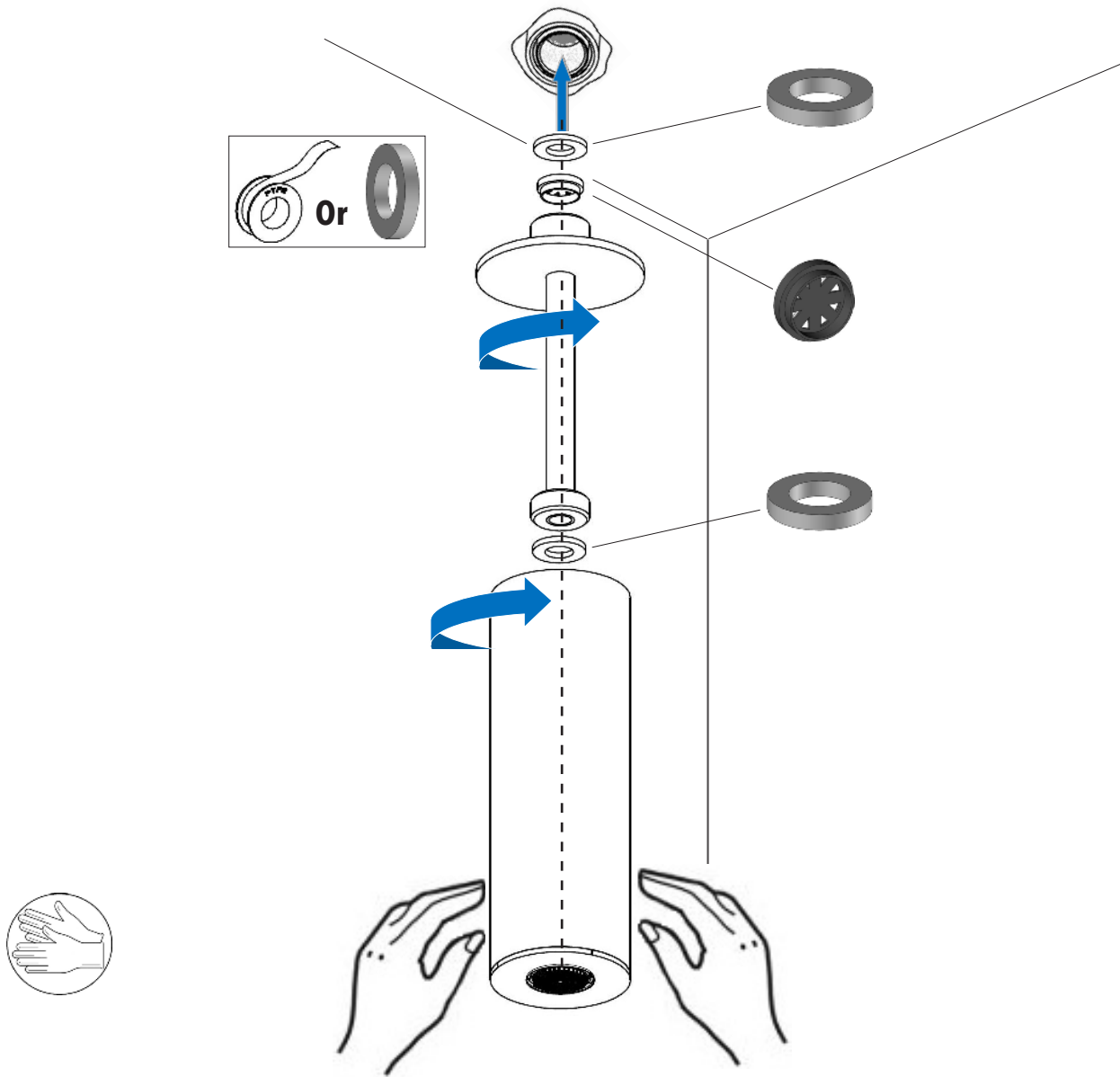

IT - Rimuovere il calcare.
 EN - Remove the limescale.
 DE - Entfernen Sie den Kalk.
 FR - Enlever le calcaire.

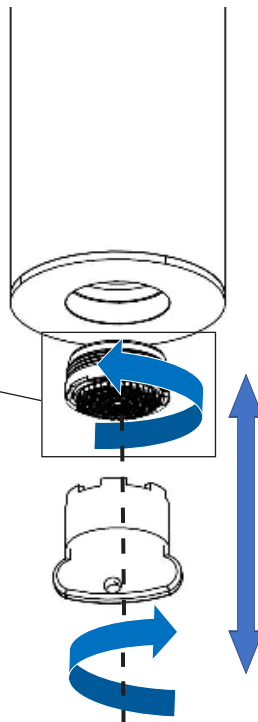
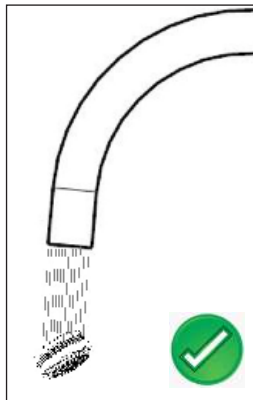



DO NOT USED DETERGENT

CH₃CH₂OH

HCL

H₂SO₄

CL

H₃PO₄

OR OTHER CORROSIVE



IT - LA GARANZIA DEL PRODOTTO NON COPRE

L'utilizzo improprio.

L'errata predisposizione dell'impianto idraulico.

Danni causati da depositi di calcare o altre impurità.

Detergenti non adatti.

EN - NOT COVERED BY PRODUCT CARE

Not correct use.

Incorrect setup of the hydraulic system.

Water impurities or limeston.

Not suitable detergents.

DE - DIE PRODUKTGARANTIE DECKT NICHT AB

Fehlerhafte Verwendung.

Die falsche Anordnung des Hydrauliksystems.

Schäden durch Kalkablagerungen oder andere

Verunreinigungen.

Ungeeignete Reiniger.

FR - LA GARANTIE DU PRODUIT NE COUVRE PAS

Utilisation incorrecte.

La mauvaise disposition du système hydraulique.

Dommages causés par des dépôts de calcaire ou

d'autres impuretés.

Nettoyants inappropriés.



IT - DUE ANNI DI GARANZIA DEL PRODOTTO

Contro i difetti o vizi di fabbricazione.

EN - TWO-YEAR PRODUCT CARE

Against defects or defects of fabrication.

DE - ZWEI JAHRE PRODUKTGARANTIE

Gegen Mängel oder Herstellungsfehler

FR - GARANTIE DE PRODUITS DE DEUX ANS

Contre les défauts de fabrication ou les défauts.

IT - ATTENZIONE: Si declina ogni responsabilità relativa ad eventuali inesattezze contenute in queste istruzioni dovute ad errori di trascrizione.

EN - WARNING: We decline all responsibility and eventual inaccuracy contained in the instructions due to transcript errors.

DE - ACHTUNG: Wir lehnen jede Verantwortung für Ungenauigkeiten in diesen Anweisungen aufgrund von Transkriptionsfehlern ab.

FR - ATTENTION: Nous déclinons toute responsabilité pour toute inexactitude contenue dans ces instructions en raison d'erreurs de transcription.