

# REMER

RUBINETTERIE

SCHEDA TECNICA

TECHNICAL FEATURES

ART. COD.

**QD10G**

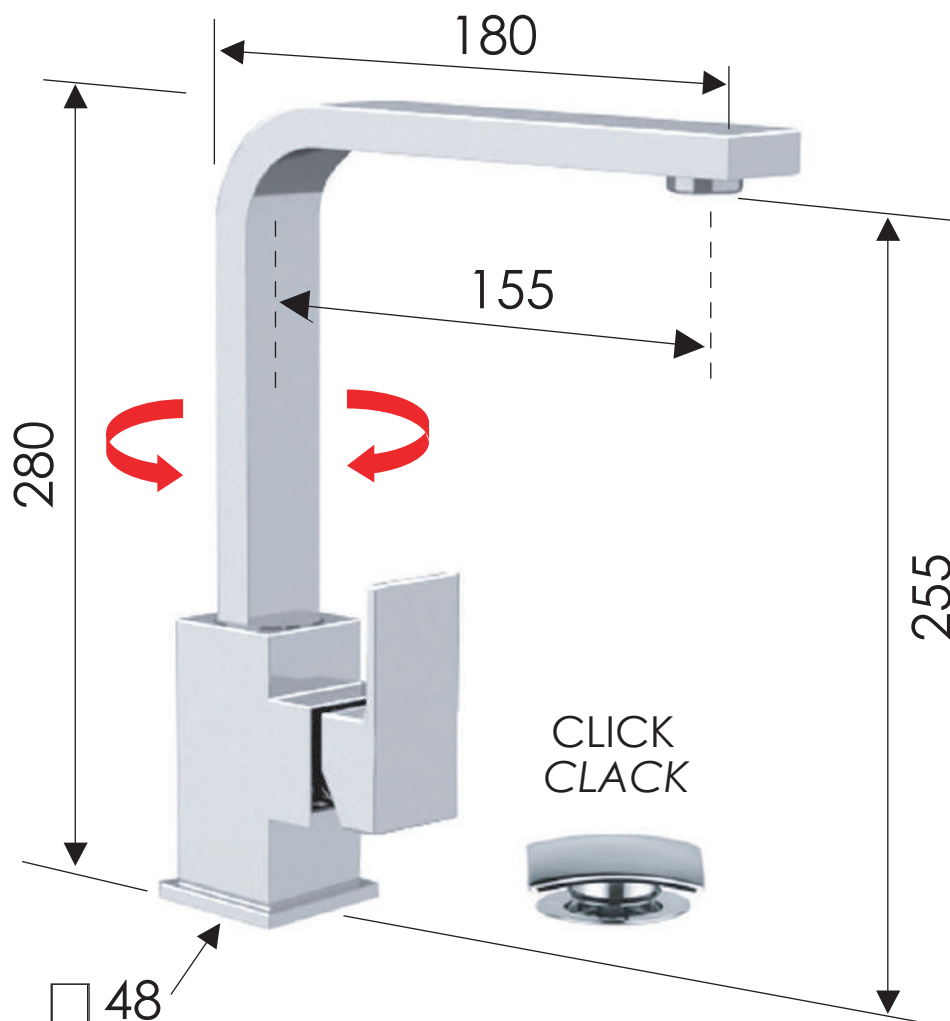

PRESSIONE / PRESSURE	1	2	3	4	5	bar
PORTATA / FLOW RATE	9	12	15	18	21	l/min

## MATERIALI / MATERIALS

OTTONE CROMATO / CHROME PLATED BRASS

## CROMATURA / CHROME PLATING

UNI EN 248

Via Leonardo da Vinci 83 - 20062 Cassano d'Adda (MI) Italy - Tel. +39-0363 364211

[info@remer.eu](mailto:info@remer.eu) [www.remer.eu](http://www.remer.eu)