

# REMER

RUBINETTERIE

SERIE  
SERIES

# SENSOR

CODICE  
CODE

# SE17

## IMMAGINE - IMAGE



## DESCRIZIONE - DESCRIPTION

Miscelatore elettronico lavabo ad azionamento a sensore con regolazione temperatura tramite rubinetto sottolavabo.

Sensor control basin mixer with angle valve for temperature adjustment.

## SCHEDA TECNICA - TECHNICAL FEATURES

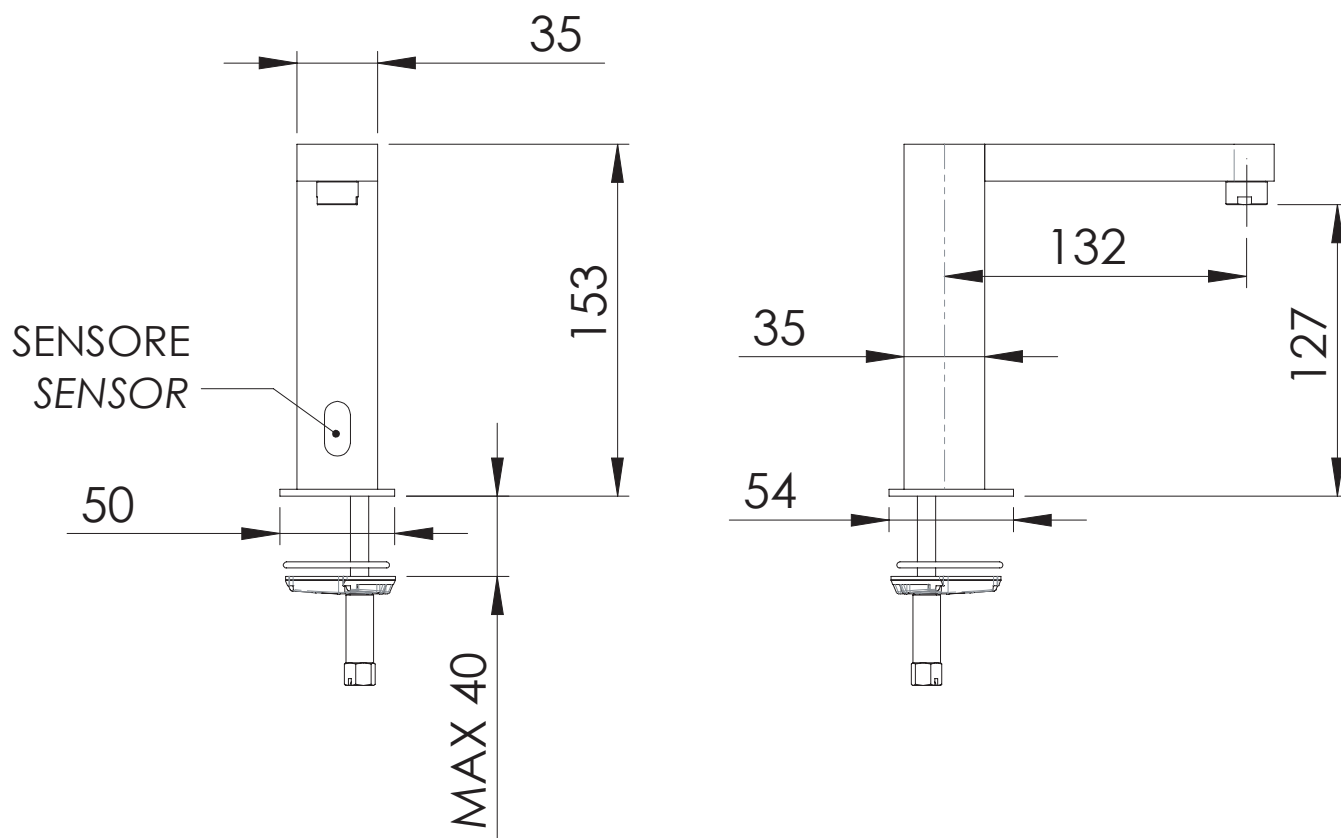

## CARATTERISTICHE - FEATURES



Azionamento a Sensore  
Sensor Control



Con filtro incluso  
With filter included

## COMPONENTI - COMPONENTS



Aeratore 83N41  
Aerator 83N41

## FINITURE - FINISHING



CR  
Cromo  
Chrome

REMER Rubinetterie S.p.A.

Via Leonardo Da Vinci, 83 - 20062 Cassano d'Adda (MI) - Italy - Tel. +39 0363 364211 - info@remer.eu - www.remer.eu