

REMER

RUBINETTERIE

SCHEDA TECNICA

TECHNICAL FEATURES

ART. COD.

332RES

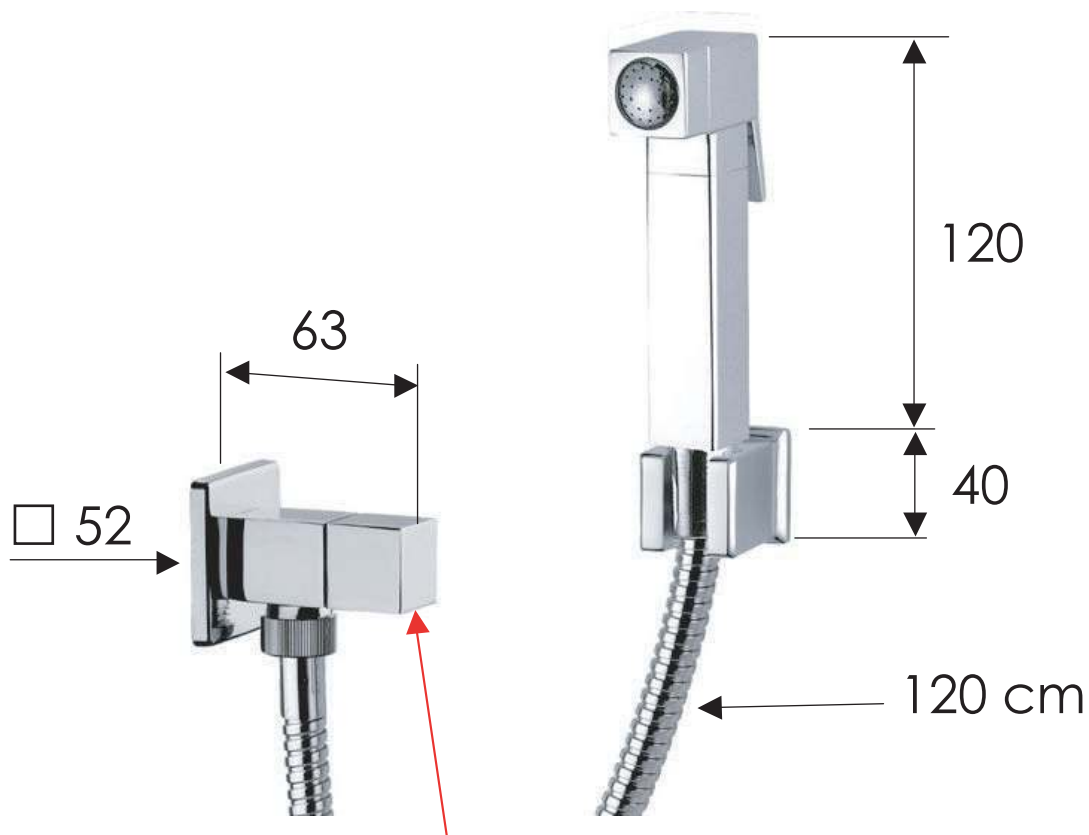

CHIUDERE IL RUBINETTO
DOPO L'UTILIZZO
ALWAYS CLOSE
THE ANGLE VALVE
AFTER USE

PRESSIONE / PRESSURE	0,5 bar	1bar	2bar	3bar	4 bar	5bar
PORTATA / FLOW RATE	7 l/min	10,5 l/min	13 l/min	15 l/min	16,5 l/min	18.5 l/min

MATERIALI / MATERIALS

OTTONE CROMATO / CHROME PLATED BRASS
CW617N - CW506L - UNI EN 12165

CROMATURA / CHROME PLATING

UNI EN 248

Via Leonardo da Vinci 83 - 20062 Cassano d'Adda (MI) Italy - Tel. +39-0363 364211

info@remer.eu www.remer.eu