

**SCHEDA TECNICA**

**TECHNICAL FEATURES**

ART. COD.

**SS X 30 L**

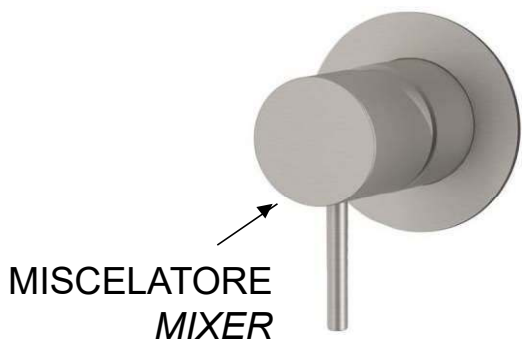

ACQUA FREDDA  
COLD WATER

G1/2

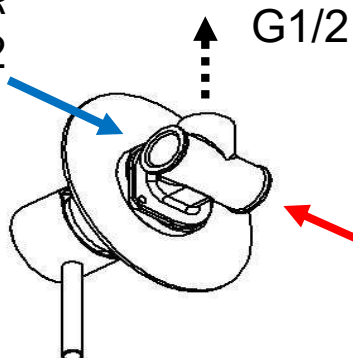

ACQUA  
CALDA  
HOT  
WATER  
G1/2

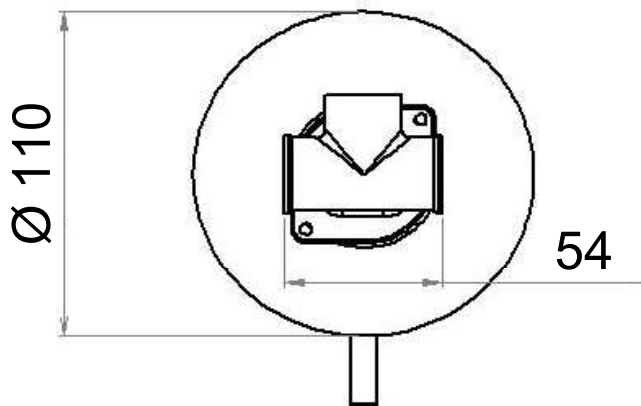
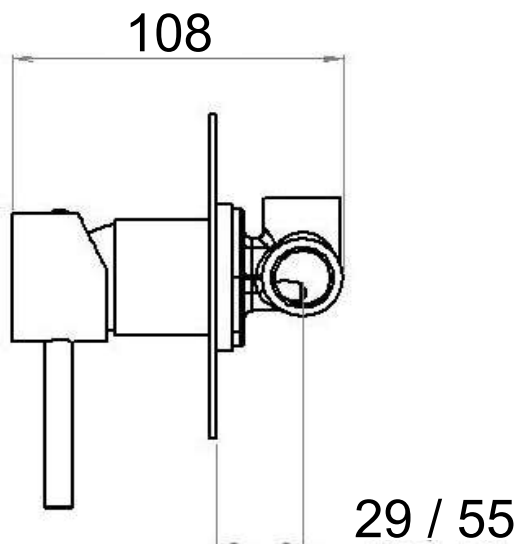

**MATERIALI / MATERIALS**

ACCIAIO INOX 316L / STAINLESS STEEL 316L

OTTONE / BRASS

Via Leonardo da Vinci 83 - 20062 Cassano d'Adda (MI) Italy - Tel. +39-0363 364211

[info@remer.eu](mailto:info@remer.eu) [www.remer.eu](http://www.remer.eu)