

REMER

RUBINETTERIE

ISTR064 Rev. 1 31-01-2025 - art. WBOX98D2/WBOX98D3/WBOX98D4/WBOX98D5
BOX INCASSO PER MISCELATORE VASCA-DOCCIA CON CARTUCCIA PROGRESSIVA
E VITONI CERAMICI APRI/CHIUDI PER COMANDARE 2/3/4/5 VIE.

INSTALLAZIONE VERTICALE O ORIZZONTALE.

BUILT-IN BOX FOR BUILT-IN BATH-SHOWER MIXERS WITH A PROGRESSIVE CARTRIDGE
AND CERAMIC DISC TURN ON/OFF VALVES TO CONTROL 2/3/4/5 INDIVIDUAL OUTLETS.

VERTICAL OR HORIZONTAL INSTALLATION.

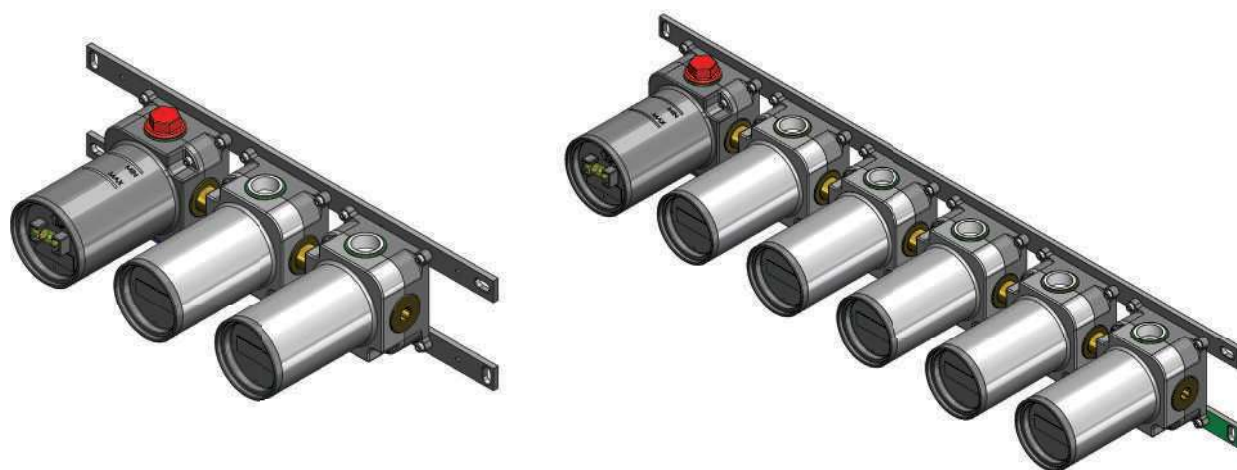

Remer Rubinetterie S.p.A.

20062 Via Leonardo da Vinci, 83 - Cassano d'Adda (MI) Italy

Tel. +39 0363 364 211 - e-mail: info@remer.eu

www.remer.eu

**ESEMPIO DI
INSTALLAZIONE
ORIZZONTALE
HORIZONTAL
INSTALLATION
EXAMPLE**

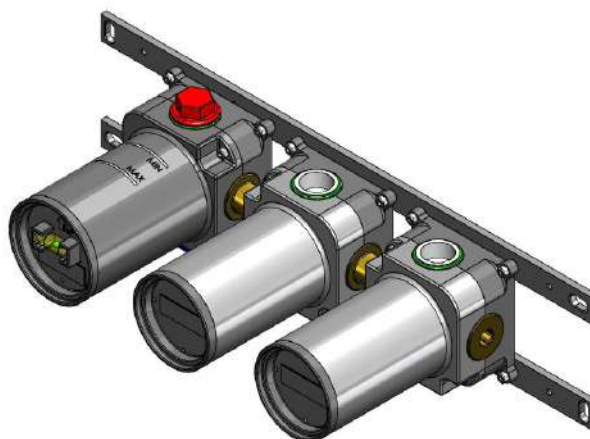

**PARTI
ESTERNE
EXTERNAL
PARTS**

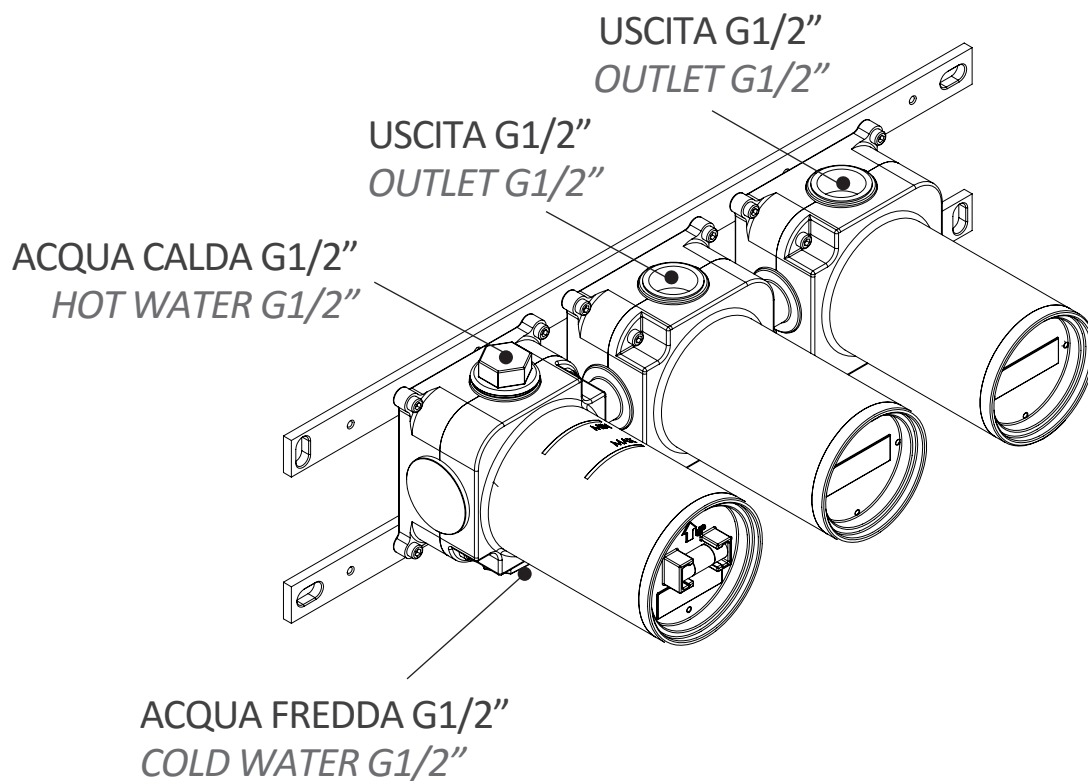
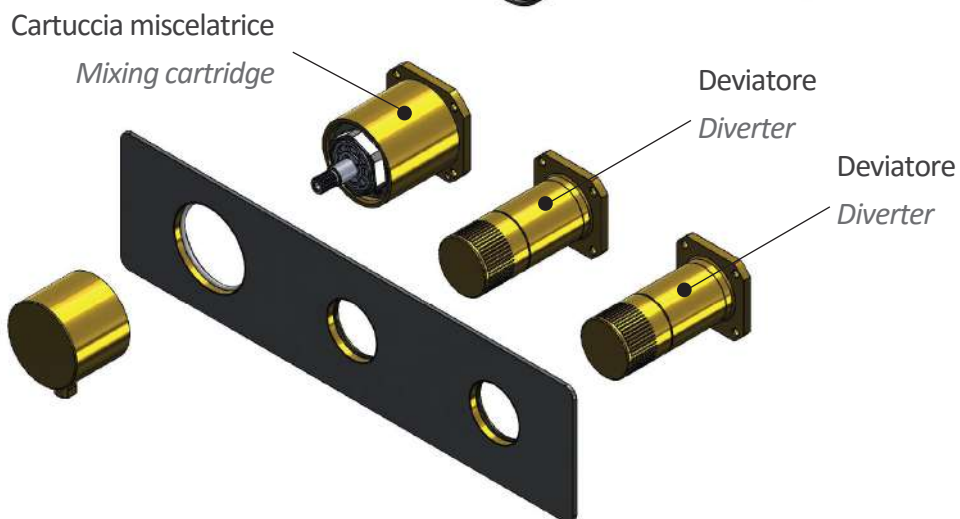

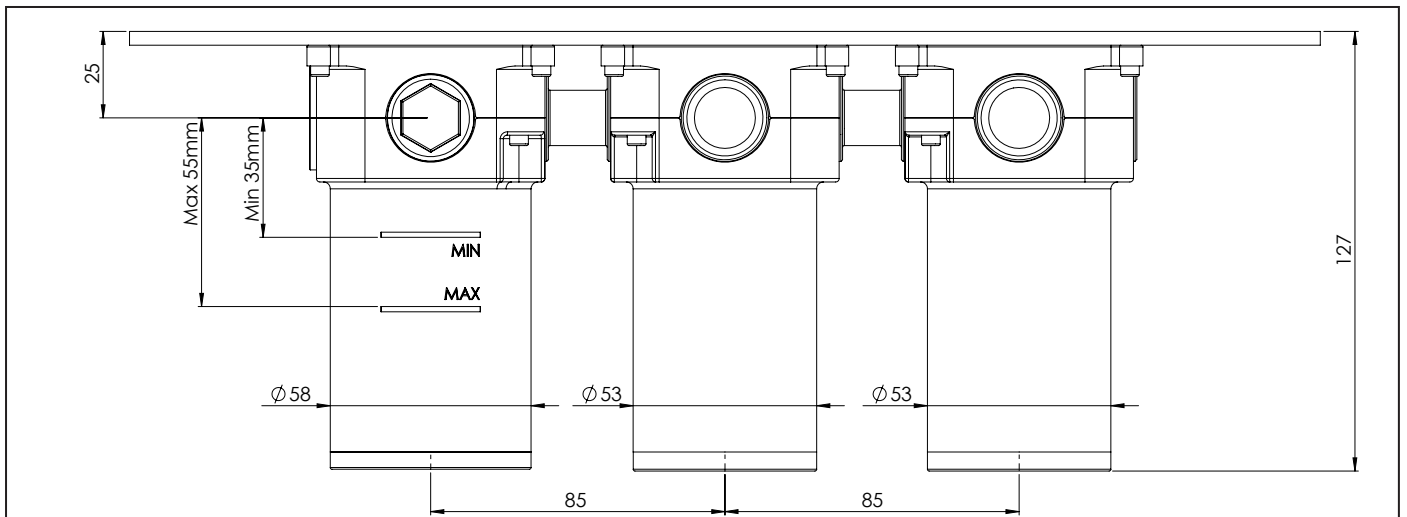

WBOX98D2

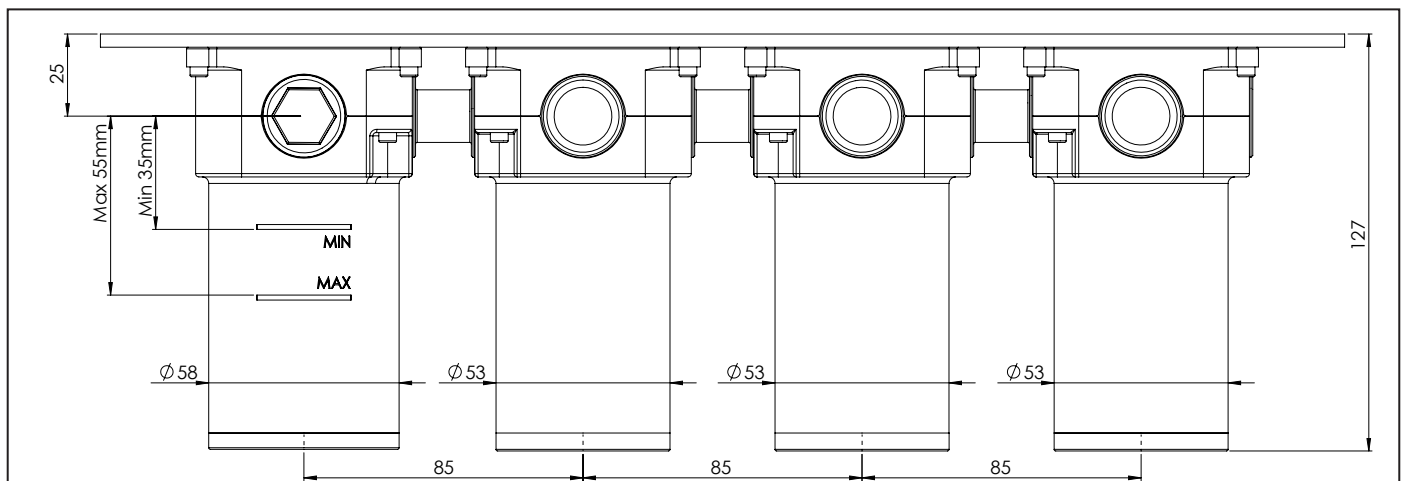
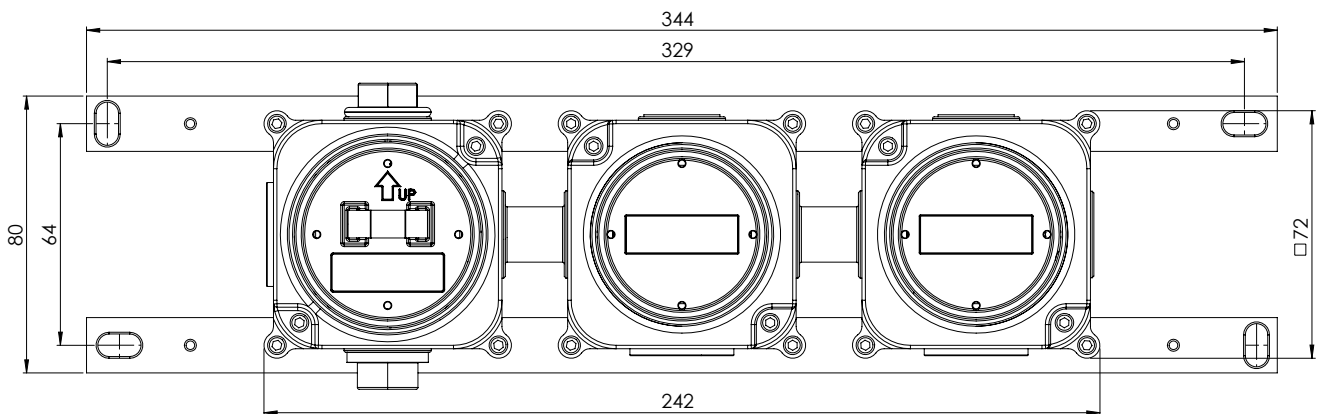

WBOX98D3

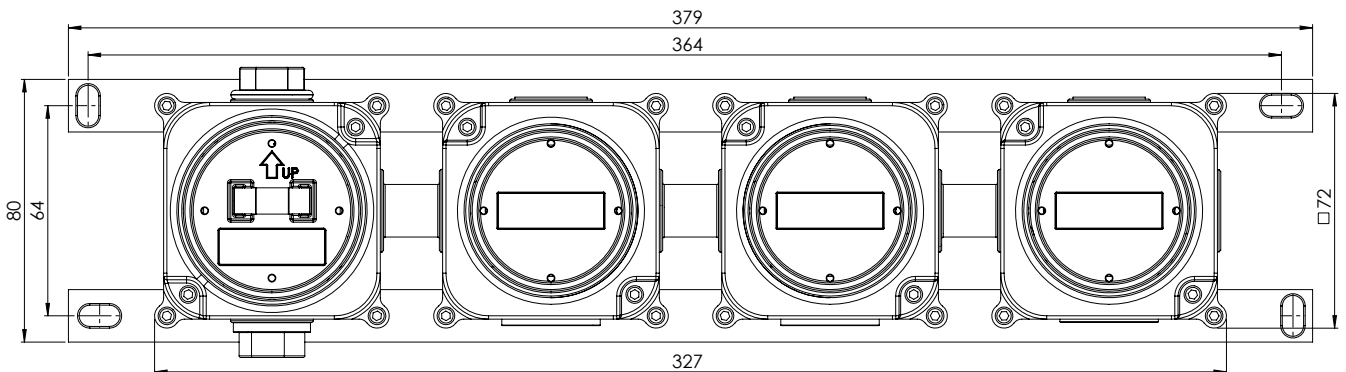

WBOX98D4

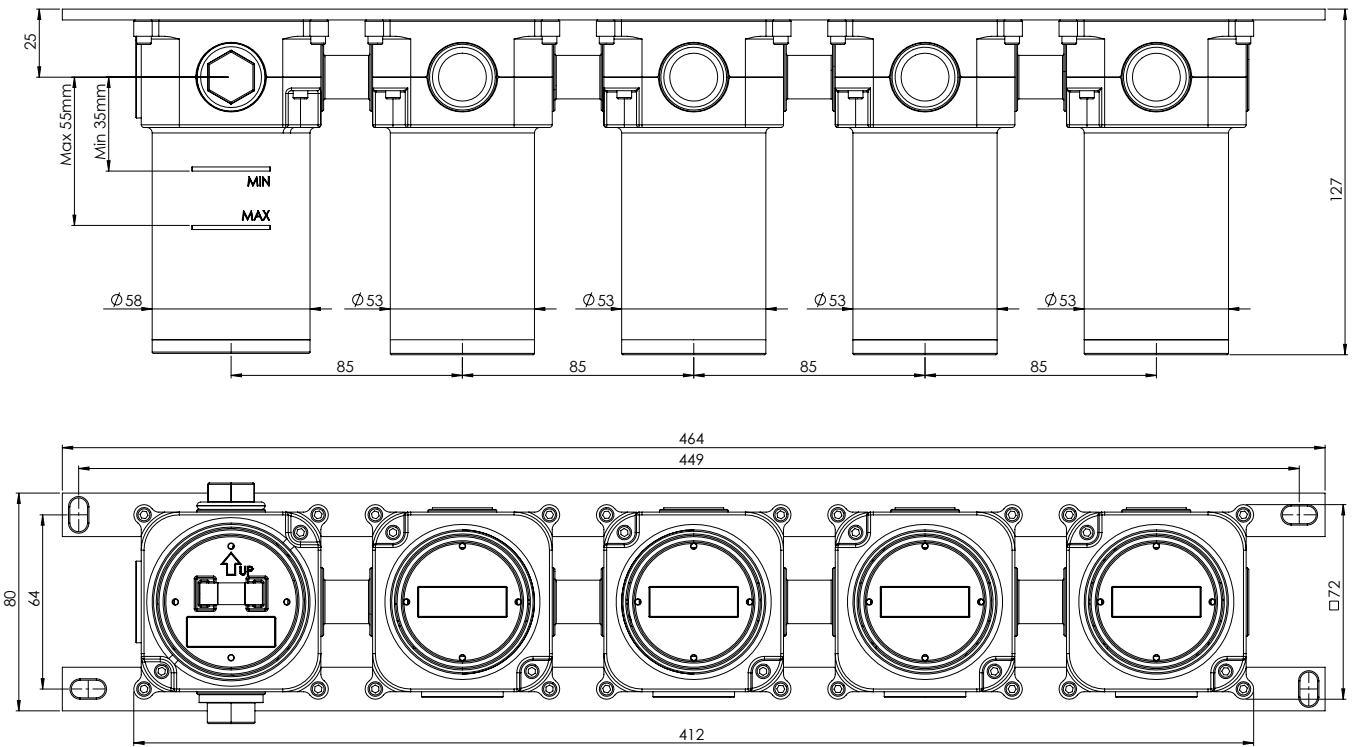

WBOX98D5

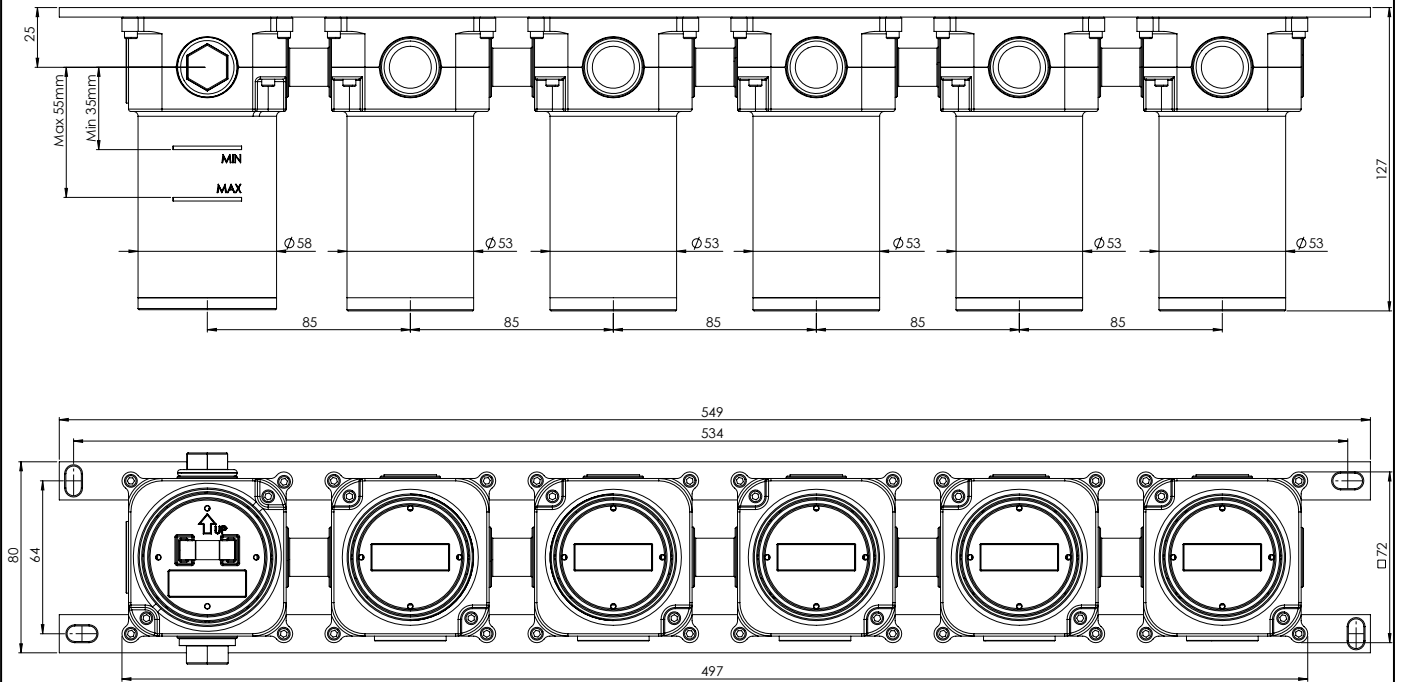

ATTENZIONE: prima di procedere con l'installazione del prodotto, verificare il corretto funzionamento dell'impianto. Le tubature devono essere libere da impurità e accumuli di calcare, temperatura e pressione di esercizio sono rispettivamente 5°Min-65°Max e 1bar-5bar.

WARNING: before proceeding with the installation of the product, check the correct functioning of the system. The pipes must be free from impurities and accumulations of limestone, temperature and operating pressure are respectively 5°min-65°Max and 1Bar-5bar.

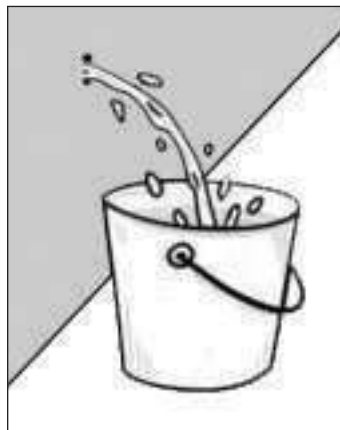

MIN 5°C
MAX 65°C

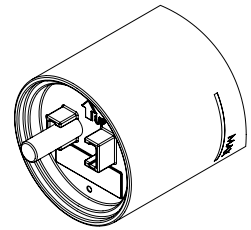
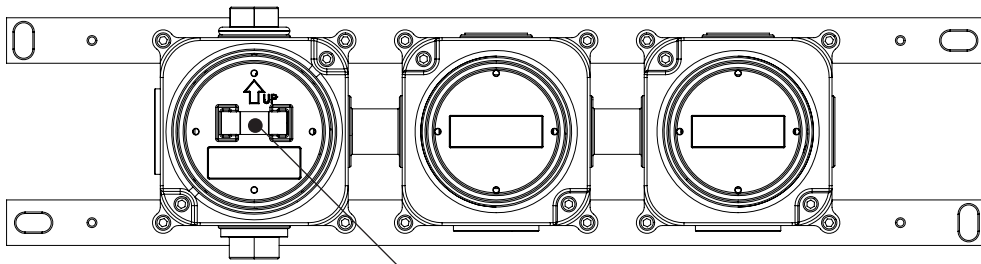

ATTENZIONE!

Verificare il corretto orientamento dell'incasso tramite la livella a bolla già montata sul coperchio.
NB: la livella a può essere ruotata di 90° per verificare il corretto orientamento delle altre direzioni.

WARNING!

Use the spirit level already mounted on the cover to check the correct orientation of the installation.
NOTE: the spirit level can be rotated 90° to check the correct orientation of the other directions.

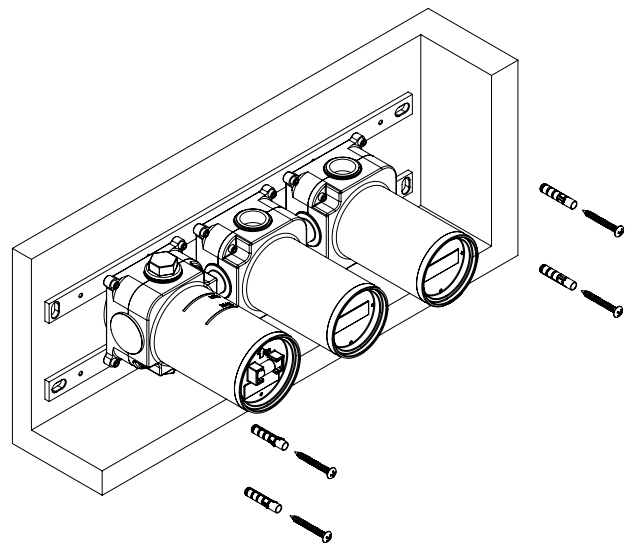
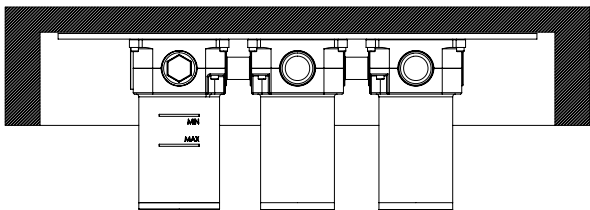

Creare una nicchia nel muro in modo tale che, una volta fissato il box incasso al suo interno, il bordo del muro finito e piastrellato sia compreso tra le due linee MIN & MAX stampate sul box incasso.

Create a housing in the wall so that, once the built-in box is secured inside it, the edge of the finished and tiled wall is between the two lines in relief (MIN & MAX) printed on the box itself.

Fissare il box incasso al muro con quattro viti e tasselli da 6mm tramite piastra di ancoraggio.
N.B.: la Box può essere murata oppure installata su legno o cartongesso tramite apposite viti di fissaggio.

*Secure the built-in box to the wall with four screws and 6mm dowels, using a fixing plate.
Note: the box can be walled in or installed on wood or plasterboard using special fixing screws.*

Collegare le tubazioni acqua calda e fredda seguendo le indicazioni sul box incasso.

Connect the hot and cold water pipes as indicated on the built-in box.

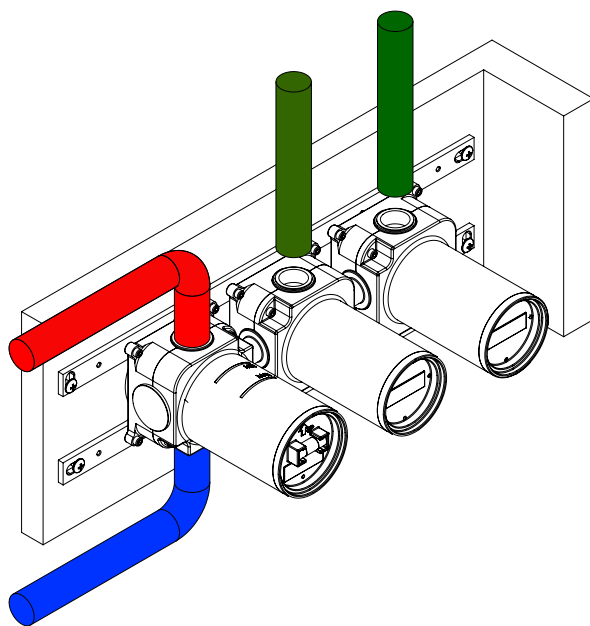
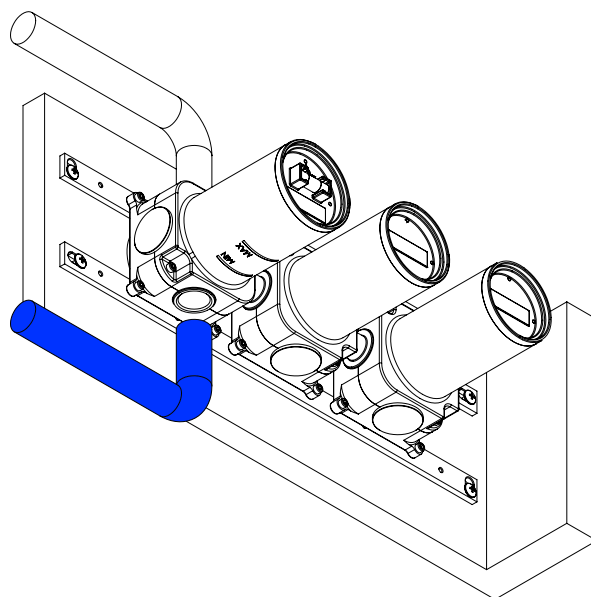
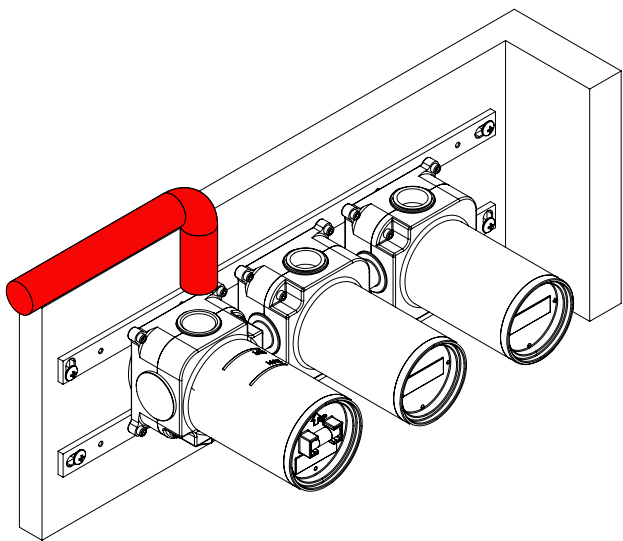

Collegare le 2/3/4/5 uscite G1/2" .

Connect the 2/3/4/5 G1/2" outlets.

Effettuati gli allacciamenti, procedere con la prova impianto ad una pressione massima di 5bar utilizzando i tappi di prova già assemblati sull'incasso.

Once the connections have been made, proceed with the system test at a maximum pressure of 5bar using the test plugs already assembled on the recess.

Se la prova impianto non presenta problemi, procedere con la finitura della parete.

If the installation test shows no problems, proceed with finishing the wall.

Installare il tappetino impermeabilizzante in dotazione incollandolo al muro grezzo.
Successivamente terminare la piastrellatura.

Install the supplied waterproofing tile by gluing it to the raw wall. Then finish the tiling.

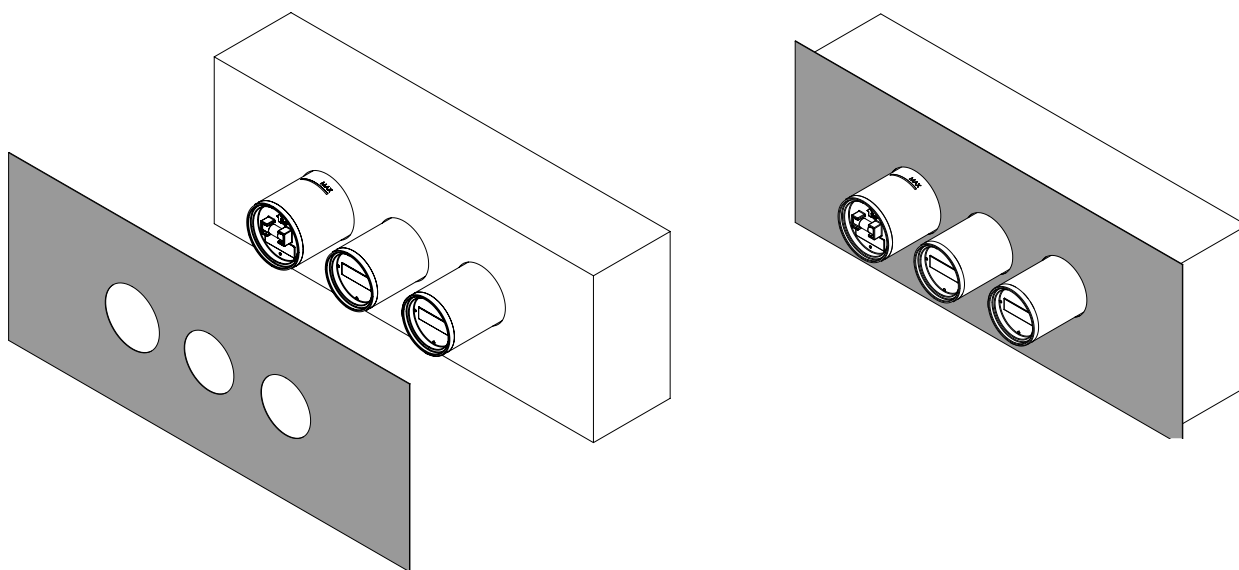

Per la finitura della parete utilizzare la dima di carta in dotazione nella confezione per forare la piastrella con il giusto interasse. Utilizzare una fresa a tazza da $\varnothing 60\text{mm}$ per la foratura.

For wall finishing, use the supplied paper template in the packaging to drill the tile with the correct spacing. Use a $\varnothing 60\text{mm}$ cup cutter for drilling.

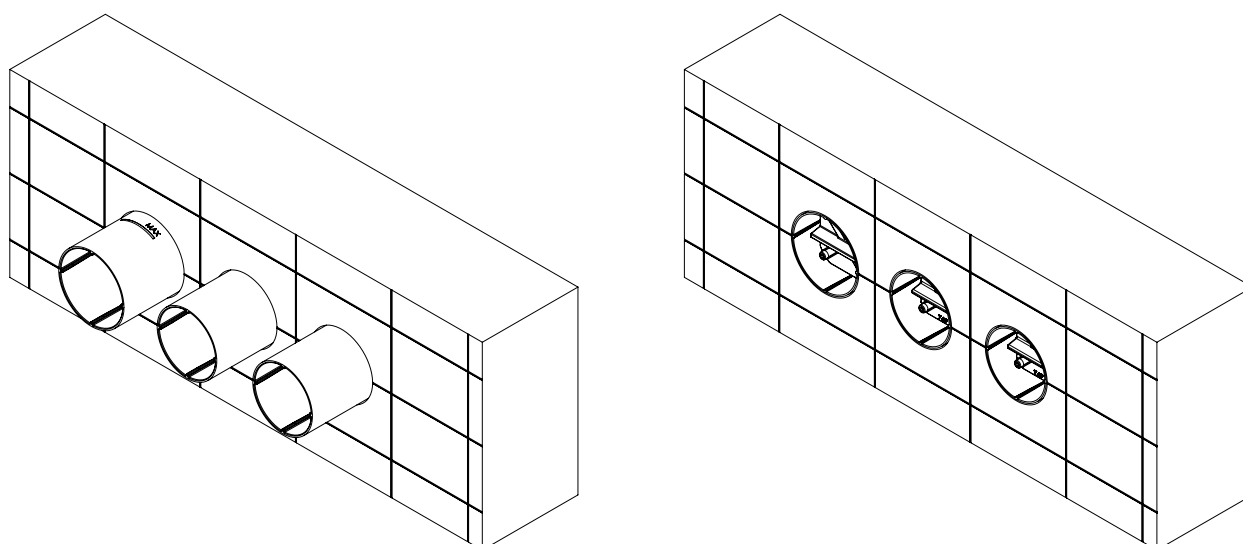

Una volta piastrellato, rimuovere i coperchi e tagliare la parte del box in eccesso.

Once tiled, remove the covers and cut off the excess part of the box.

INSTALLAZIONE PARTE ESTERNA

EXTERNAL PART INSTALLATION

Rimuovere i tappi di prova impianto e assicurarsi che l'alloggiamento delle parti esterne sia privo di elementi per evitare problemi di funzionamento del prodotto.

NB: insieme ai tappi di prova, assicurarsi di rimuovere anche il relativo OR di tenuta.

Remove the system test plugs and ensure that the housing of the external parts is free of elements to avoid product malfunctions.

NOTE: be sure to also remove the corresponding sealing O-rings.

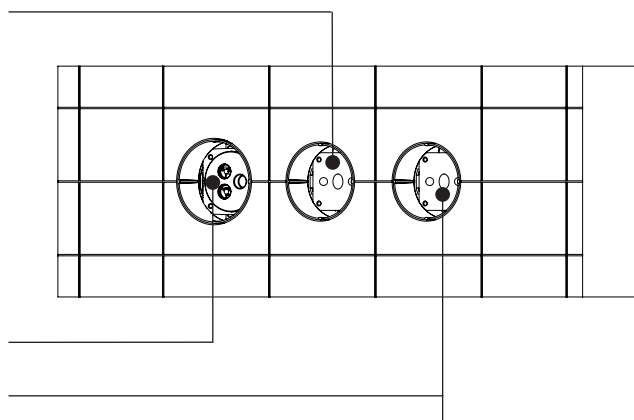

Installare le parti esterne serrando le viti al corpo incasso. Sarà necessaria una chiave a brugola di misura 2.5.

Install the external parts by tightening the screws to the built-in body. An Allen key size 2.5 is needed.

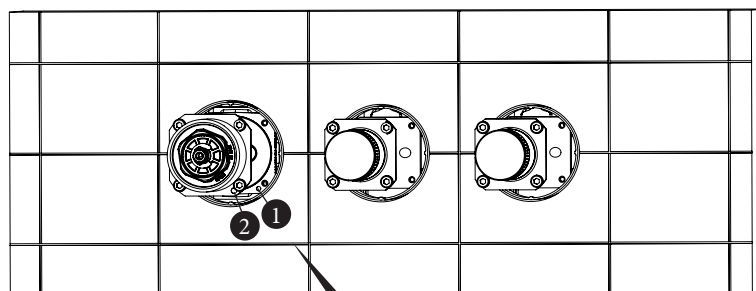
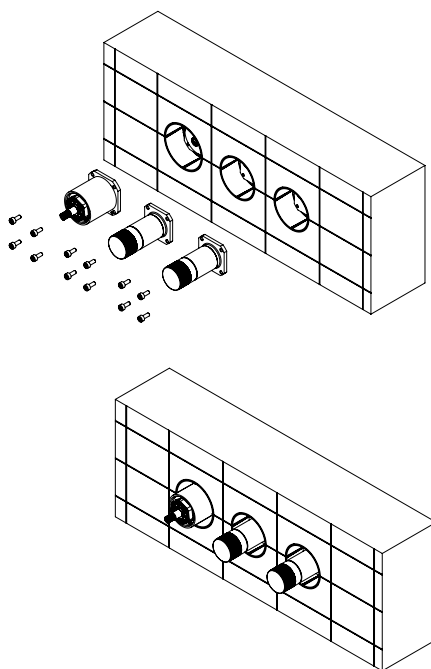

NB: la coppia di fori 1-2 deve essere allineata per garantire il corretto orientamento delle parti esterne. I vitoni non hanno bisogno di essere orientati in una posizione particolare e possono essere installati liberamente.

NOTE: the pair of holes 1-2 must be aligned to ensure the correct orientation of the external parts. Head valve do not need to be oriented in a particular position and can be installed freely.

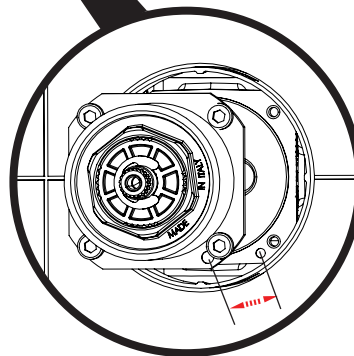

Per installare correttamente la piastra, ingrassare leggermente gli OR in modo da facilitarne lo scorrimento sui bicchieri. Siliconare la piastra in modo da lasciare il lato inferiore libero dal silicone per permettere ad un eventuale perdita di fuoriuscire dall'incasso.

To install the plate correctly, lightly grease the O-rings in order to make them easier to slide on the cups. Silicon the plate so that the underside is free of silicone to allow any leakage to escape from the built-in part.

Applicare del grasso sugli OR.
Apply grease to O-rings.

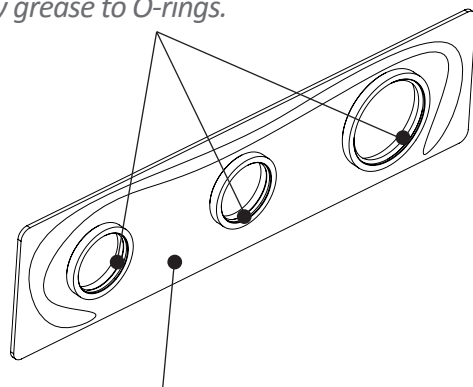

Spazio privo di silicone.
Silicone-free space.

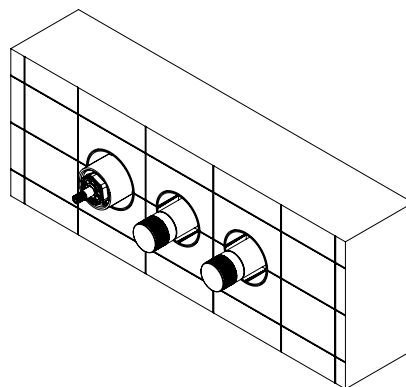

Assemblare la leva. Sarà necessaria una chiave a brugola di misura 2.5.

Assemble the lever. An Allen key size 2.5 is needed.

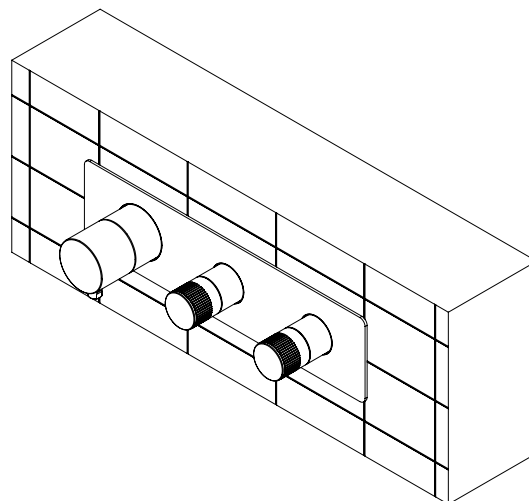
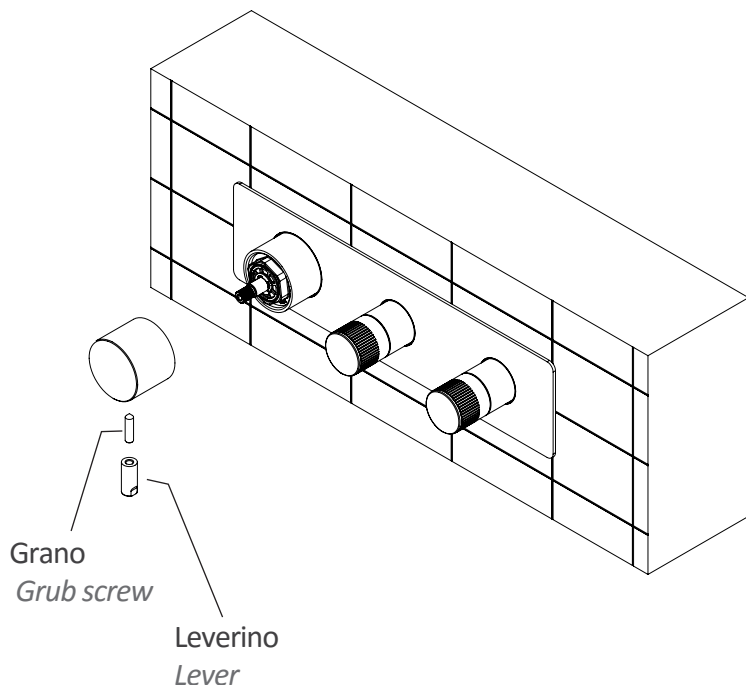

REMER

RUBINETTERIE

Remer Rubinetterie S.p.A.

20062 Via Leonardo da Vinci, 83 - Cassano d'Adda (MI) Italy

Tel. +39 0363 364 211 - e-mail: info@remer.eu

www.remer.eu