

REMER

RUBINETTERIE

SERIE
SERIES

DREAM

CODICE
CODE

D10

IMMAGINE - IMAGE



SCHEMA TECNICA - TECHNICAL FEATURES

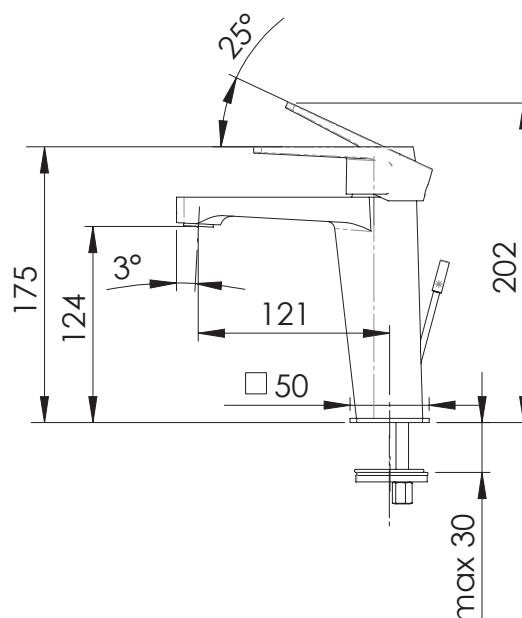

DESCRIZIONE - DESCRIPTION

Miscelatore monocomando lavabo con scarico.

Single-lever basin mixer with pop-up waste.

CARATTERISTICHE - FEATURES



Disponibile in Finitura
Available in Finishing



Perfect Tune
Perfect Tune



Con scarico
With pop-up waste

COMPONENTI - COMPONENTS



Cartuccia R50
Cartridge R50



Aeratore 83Z40
Aerator 83Z40

FINITURE - FINISHING



NO
Nero Opaco
Matt Black



BO
Bianco Opaco
Matt White



DO
Oro Lucido
Shiny Gold



CR
Cromo
Chrome

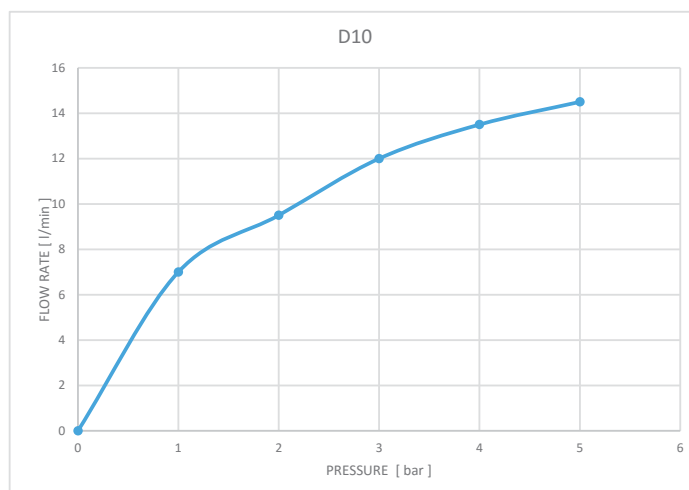

0	1	2	3	4	5	PRESSURE	bar
0	7	9,5	12	13,5	14,5	FLOW RATE	l/min

REMER Rubinetterie S.p.A.

Via Leonardo Da Vinci, 83 - 20062 Cassano d'Adda (MI) - Italy - Tel. +39 0363 364211 - info@remer.eu - www.remer.eu